

Fastening Performance of A Bolted Joint using A Hexagon Bolt with Flange

Minoru TANAKA*

(Received October 15, 1992)

I Introduction

In Japanese Industrial Standard (JIS hereafter), the hexagon head bolt and the hexagon bolt with flange (flange bolt hereafter) are standardized. Although these two types of the bolts have some different characteristics from each other, they are treated in JIS as a same typed bolt. However, the theoretical background of JIS concerning with this standardization has been not clear so far. It may be important to investigate precisely the characteristics of these two types of the bolt using an aculeate analyzing method such as a finite element method.

The flange bolt has some particular features compared with the hexagon head bolt as follows:

- (1) The plain washer is unnecessary for this bolt.
- (2) Compression on the bearing surface of this bolt is lower than that of the hexagon head bolt^{1),2)}.
- (3) Loosening troubles with this bolt are not significant compared with the hexagon head bolt³⁾.

For the flange bolt, there are two types of bolt head shape called the first and second type shapes. The first type shape is that the hexagon head is in close contact with the plain washer. On the other hand, the second type shape is that the hexagon head is in close contact with the washer which has a frustum of circular cone.

The distributed pressure on the connecting surface depends on the shape of the bolt head. Therefore, the first and second type flange bolt may be distinguished by estimating the fastening performance, although the flange bolts are used actually without distinction of the flange shape.

The fastening performances of the hexagon head bolt and of the first and second type

* Faculty of Education, Iwate University, Ueda, Morioka 020

flange bolts are effectively examined by the distributed pressure on the connecting surface.

In this paper, for investigating the effect of the bolt head shapes on the fastening performance, the distributed pressure on the connecting surface is calculated by a finite element method and the fastening performance with the different shapes of the bolt head is estimated by the distributed pressure on the connecting surface.

II Conditions for Analysis

The shape of flange bolt is shown in Fig.1. In JIS, the taper angle of the flange is defined to be 0 degree for the first type, and to be 15 to 30 degree for the second type.

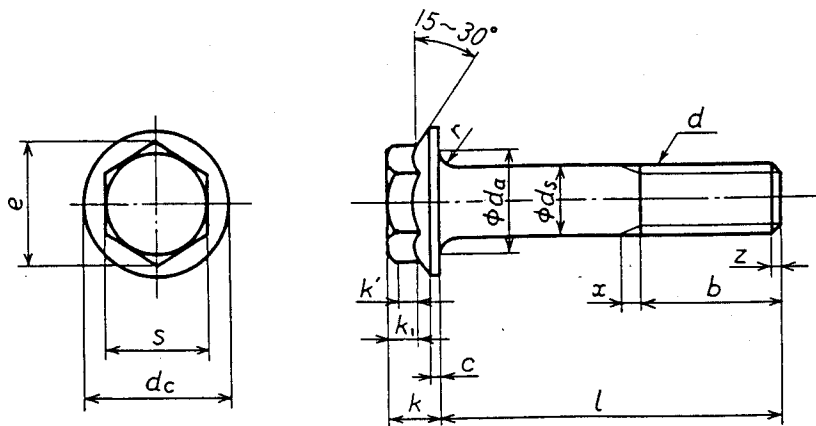

Hexagon bolt with flange

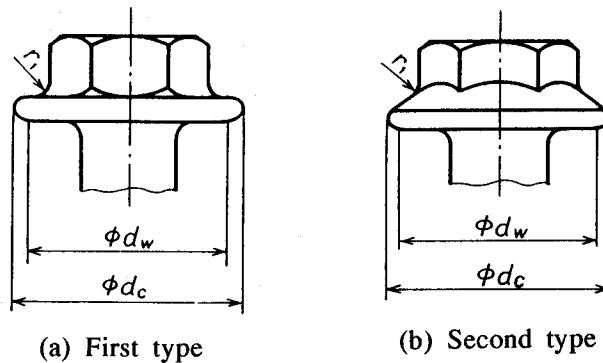

(a) First type

(b) Second type

Fig.1 Schematic illustration of flange bolt

On the other hand, only one type of the hexagon nut with flange is defined by JIS. The shape of hexagon nut with flange is almost same as that of the second type flange bolt.

Figure 2 shows the joint tightened by the flange bolt. For investigating this bolted joint

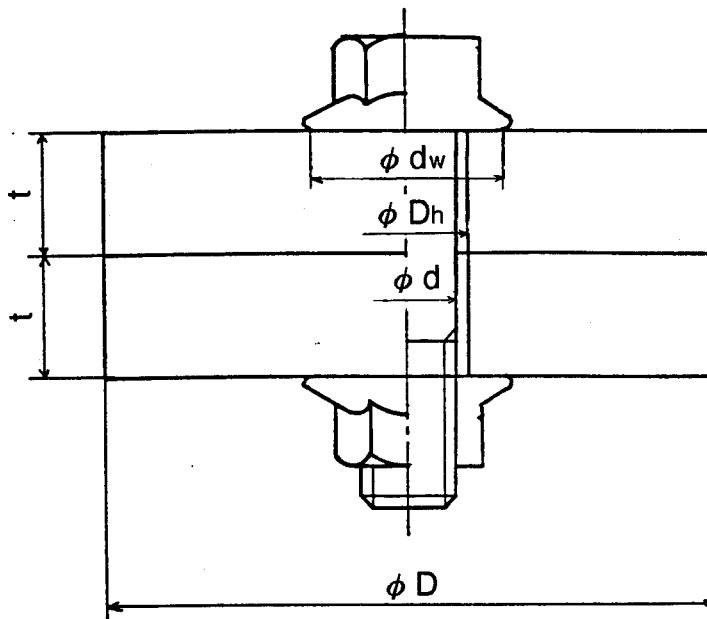

Fig.2 Bolted joint tightened by flange bolt

rigorously, a three dimensional analysis is required. In this case, however, three dimensional calculation are very complicated and take a lot of computing times. Therefore, the calculations are carried out in the axi-symmetric coordinate by replacing the hexagonal solid with a right cylinder.

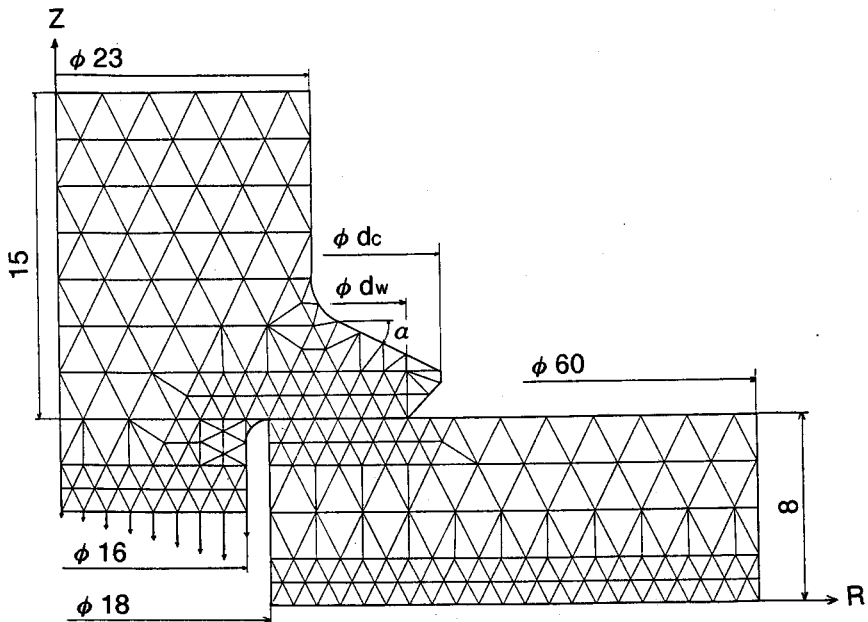

Fig.3 Meshed model of bolted joint

The bolted joint shown in Fig.2 is meshed as shown in fig.3. The boundary conditions of the mesh model shown in Fig.3 are determined so that all the nodal point of the connecting surface are fixed in the direction of Z axis for the case of no-load. When the force of the fixed node due to the deformation in the clamped plate caused by the applied load is under 0 Newton, the boundary conditions are changed so that the condition of this node is regarded as free boundary. This means that the connecting surfaces are separated as the point of this node. The calculations are repeated with these boundary conditions until the separation on the connecting surface is completed.

III Results and Discussions

Figure 4 shows the relation between the radius of the connecting surface and the pressure

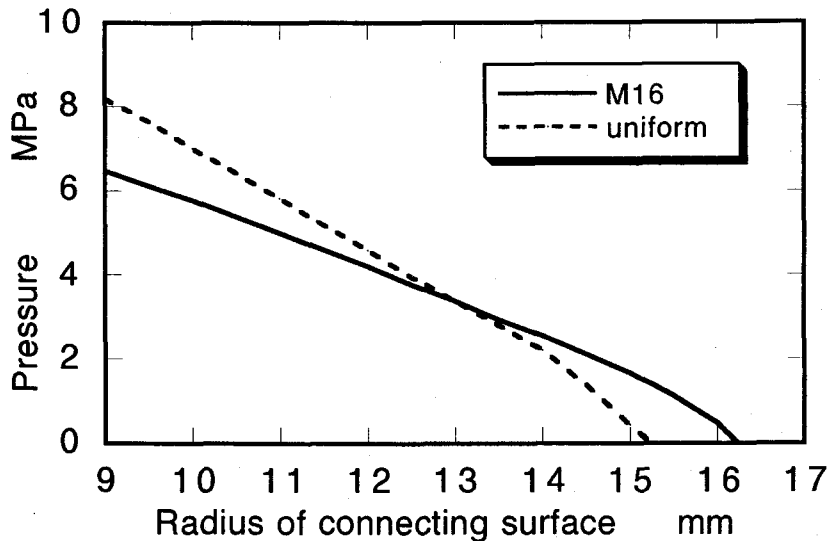

Fig.4 Relation between the radius of the contact surface and the pressure for the case of "M16" in comparison with the case of "uniform"

for the case of "M16" in comparison with the case of "uniform". In this figure, "uniform" means that the load on the area which is equal to the bearing surface of M16 hexagon head bolt defined in JIS is distributed uniformly. In this case, the bolt head is ignored.

"M16" is M16 hexagon head bolt in which the load is applied on the bolt shank.

The calculated contact region of "M16" is wider than that of "uniform". This may be caused by the fact that the bolt head of "M16" is deformed by the applied load. On the other hand, for the case of "uniform", only the deformation of the bearing surface takes place by the applied load. Therefore, it is necessary for the analysis to consider the shape of bolt head.

The relation between the radius of the connecting surface and the pressure of the

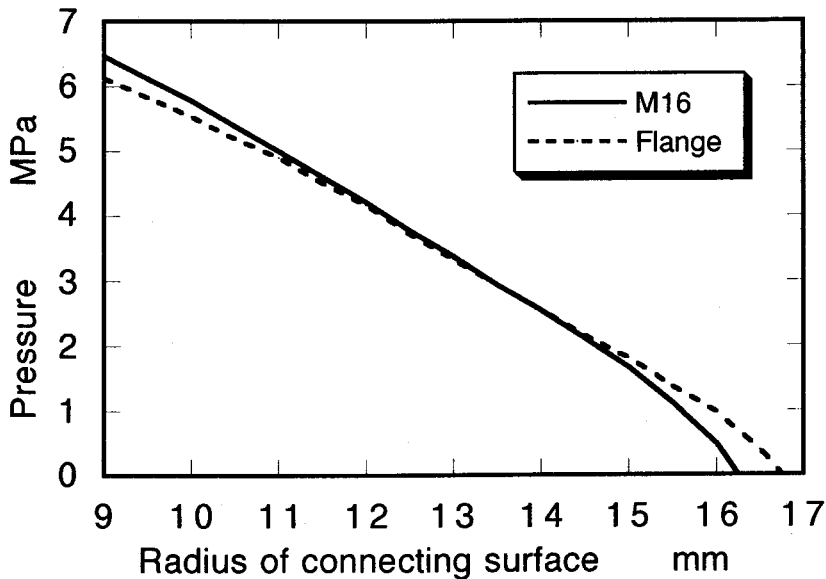

Fig.5 Relation between the radius of the contact surface and the pressure of the hexagon head bolt in comparison with the flange bolt

hexagon head bolt in comparison with the flange bolt is shown in Fig.5. In this figure, "M16" is M16 hexagon head bolt and "Flange" is M16 flange bolt of the first type.

The calculation shows that the distributed pressure of "M16" is higher than that of "Flange" at the bolt hole edge and the contact region of "Flange" is wider than "M16". Since it is clear that the area of the bearing surface of "Flange" is wider than that of "M16", the calculated results on the distributed pressure indicate that the distributed pressure of "Flange" at the bearing surface edge is higher than that of "M16". This may be also caused by the fact that the deflection of "Flange" is larger than that of "M16", because the hexagon head size of the flange bolt in JIS is one size smaller than that of the hexagon head bolt.

It may be concluded from the results of the calculation that using the flange bolt is effective for sealing and sinking of the bearing surface, because of the wide contact region on the connecting surface and the low distributed pressure at the bolt hole edge.

The relation between the radius of the connecting surface and the pressure of the flange bolt with change of the taper angle of the flange is shown in Fig.6. In this case, the height of the head and the diameter of the bearing surface are taken to be constant. The height and the diameter are respectively 15mm and 30mm. In this case, the shape of the bolt head is same as the first type flange bolt where the taper angle of the flange is equal to be 0 degree.

When the taper angle of the flange increases, the distributed pressure at the edge of the bolt hole is decreased and the contact region of the connecting surface is increased. This may be caused by the fact that the rigidity of the flange is increased proportionally with

increasing the taper angle of the flange. This indicates that the large taper angle of the flange is effective for fastening performance. The larger taper angle of the flange, which requires a higher bolt head in size, however, may have disadvantage for designing of the bolted joint, because of difficulty for using of a tightening tool.

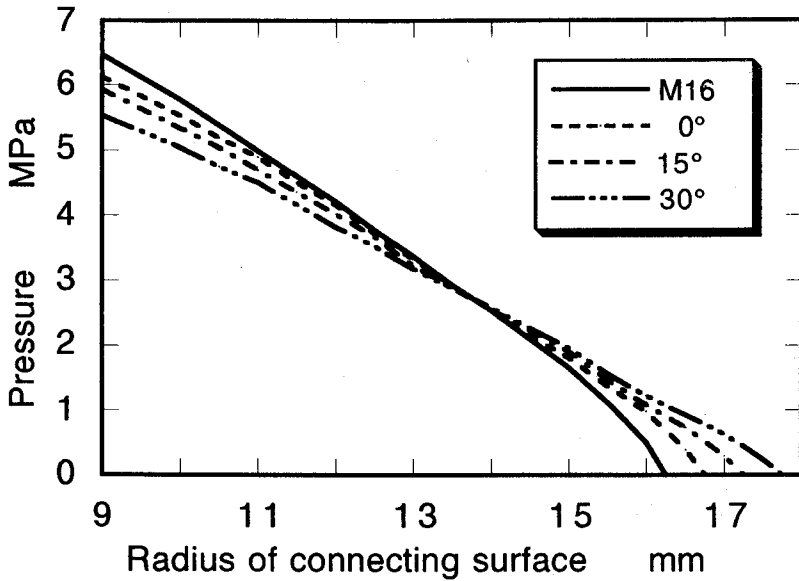

Fig.6 Relation between the radius of the contact surface and pressure of the flange bolt with change of the taper angle of the flange

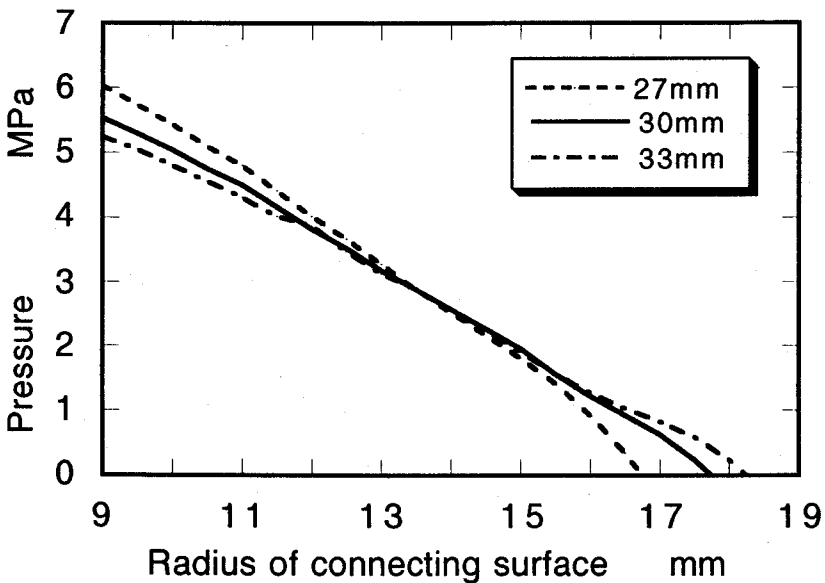

Fig.7 Relation between the radius of the contact surface and pressure of the flange bolt with change of bearing surface diameter

The relation between the radius of the contact surface and the pressure of the flange bolt with change of the bearing surface diameter is shown in Fig.7. In this case, the height of the head and the taper angle of the flange are taken to be constant. The height and the taper angle are, respectively, 15 mm and 30 degree.

It is observed that the contact region is increased with increasing diameter of the bearing surface in this figure. However, the increasing rate of the contact region by changing the diameter of the bearing surface from 30 to 33 mm is lower than that by changing the diameter of the bearing surface from 27 to 30 mm. This may be caused by the fact that the flange with the large diameter of the bearing surface has low bending rigidity and, as a result of this, the flange is deflected easily, and also the flange is sprung out by the clamping force.

IV Summary

The obtained results by the present calculations using the finite element method for the hexagon head bolt and the flange bolt are summarized as follows:

- (1) It is necessary to consider the shape of the bolt head for analysing fastening performance of the bolted joint, because the bolt head is deformed by the applied load.
- (2) The calculation results show that the contact region of the first type flange bolt is wider than that of hexagon head bolt.
- (3) When the taper angle of the flange or the diameter of the bearing surface increase, the distributed pressure at the edge of the bolt hole is decreased and the contact region of the connecting surface is increased.
- (4) The large flange angle and large diameter of the bearing surface are effective for the fastening performance. However, the larger head shape in size than that standardized in JIS may have disadvantage for designing of the bolted joint.
- (5) It is confirmed that the head shapes of the flange bolt standardized in JIS are appropriate for obtaining the proper fastening performance.
- (6) The flange bolt is effective for fastening compared with the hexagon head bolt, because the contact region of the flange bolt is wider than that of the hexagon head bolt.
- (7) The flange bolt is available for prevention of the sinking of the bearing surface and the sealing.

References

- 1) Yamamoto, A. "Introduction of Screw Thread" (in Japanese), Japanese Standard Association, 1990, p44
- 2) Yoshimoto, I. "Essential Points for Designing of The Bolted Joint", (in Japanese), Japanese

Standard Association, **1992**, p**214**

- 3) The Japan Research Institute for Screw Threads and Fasteners, "A Report of Research for Standardization on Fastening Performance of High Tension Bolt, No.3" ,(in Japanese), The Japan Research Institute for Screw Threads and Fasteners, **1980**, p**29**