

Organic materials surface hydrophilic control using atmospheric pressure plasma jets

Seiji Mukaigawa, Hiroshi Ito, Kota Nawa, Noriyuki Kita, Koichi Takaki, Tamiya Fujiwara

Department of Electrical and Electronic Engineering, Iwate University
4-3-5 Ueda, Morioka, Iwate 020-8551 Japan

Abstract: Surface modification of Polyethylene terephthalate (PET) using two types of atmospheric pressure plasma jet, silent discharge and glow type discharge, was investigated. The water contact angle of PET surface was improved by plasma treatments using the silent discharge and glow type discharge plasma jet. XPS results showed that the ratio of oxygen-containing polar group in PET increases and it is consistent with the contact angle measurement. Comparing the types of plasma treatment, there is much oxygen-containing group in the glow type discharge.

Keywords: Atmospheric pressure plasma, Plasma jet, Contact angle, XPS, PET

1. Introduction

Various technologies have been used for improving organic materials surface characteristics. Atmospheric plasma treatment is very useful method to modify a hydrophobic organic material surface to hydrophilic surface for improving wettability and adhesion properties without changing bulk properties. Hydrophilicity control is important for adhesion properties improvement at metal/organic interface and nanostructure formation on substrates. Atmospheric pressure glow plasma is the most promising technology of the surface treatment of organic materials because of the properties of effective radical generation and damage-less properties due to the low electron temperature.

In this paper, we show two types of atmospheric pressure plasma jet (APPJ) generator, which is excited by a frequency (100 kHz) AC power supply. Polyethylene terephthalate (PET) surface are modified using the two types of APPJ in order to improve the hydrophilicity of the surface.

2. Experimental Setup

Helium gas with a purity of 99.9999% is used in the experiment, and the gas flow rate is measured by a purge flow meter. The gas flow rate was controlled by a regulator. The applied voltage and current were monitored by a digital oscilloscope (Tektronix TDS3054B) through a high voltage probe (Tektronix P6015A) and Rogowski coil (Pearson CT2877), respectively. A photo-multiplier tube (Hamamatsu 1P28) are used to measure the light emitted from the discharge.

Two types of APPJ generator are shown in Fig.1 and Fig.2. An APPJ tube consists of a glass tube (inner diameter $\phi=1.85$ mm) and Cu tape as powered electrode and Cu plate as a ground electrode. The Cu tape is placed at the position of 5 mm from the edge of the glass tube.

Three APPJ tubes are placed in parallel in front of the Cu plate as shown in Fig.1 (Type 1). The distance between the Cu plate and the Cu tape was 8-13 mm. In the case of Type 1, specimen (PET) was placed on the Cu plate and exposed to plasma directly [1,2]. Type 2 consists of two

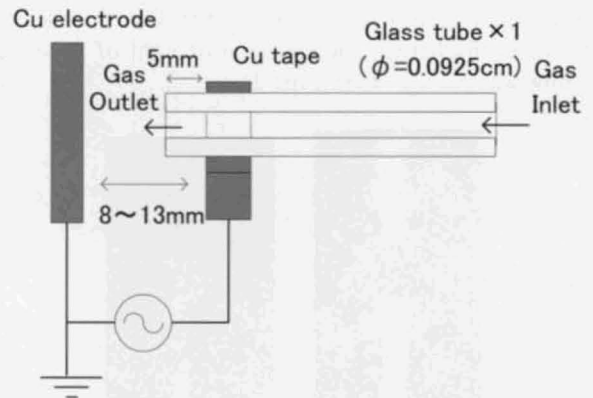

Fig.1. Schematic illustration of the Type 1

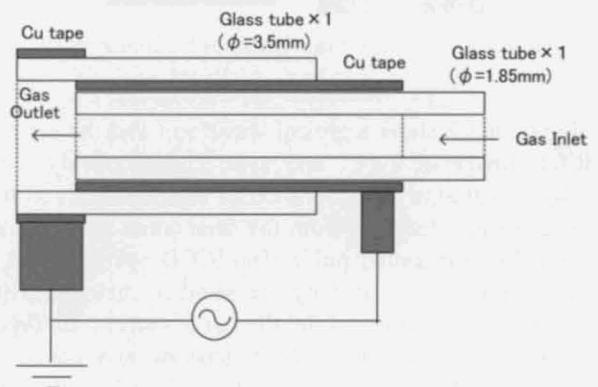

Fig.2. Schematic illustration of the Type 2

glass tubes ($\phi=1.85, 3.5$ mm) and Cu tape as powered and ground electrode. Edge of the outer glass tube is wrapped with Cu tape. The inner glass tube is inserted in the larger one and fixed in it. The inner tube electrode and outer one are connected to the ground and power supply, respectively. Helium gas was introduced into the inner tube. In the case of Type2, specimen was placed near the gas outlet and exposed to plasma indirectly [3].

Structure of the discharge was observed using ICCD camera (HAMAMATU PHOTONICS M7971-01). The water contact angle was measured using a digital microscope (Keyence VHX-100). The chemical structure was observed by the X-ray photoelectron spectroscopy (PHI-5600).

3. Results

3.1 Voltage and discharge current waveform

A digital camera photograph of an APPJ in Type 1 and Type 2 are shown in Fig.3. Voltage and discharge current waveforms during the surface treatment are shown in Fig.4 and Fig.5. The breakdown voltage V_{pp} is 2.8 kV, 1.7 kV in Type 1 and Type 2, respectively. As for the discharge current wave pattern, a single electric current pulse appears in one cycle of the sinusoidal wave in Type 1, it seems to be glow discharge. In the other, spikes-shaped discharge current pulse is observed in Type 2, it seems to be silent discharge. The emission of light of Type1 generator was stronger than Type 2.

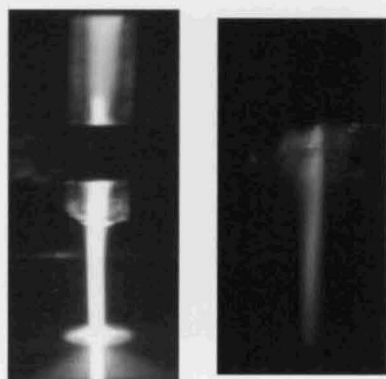

Fig.3. Pictures of a discharge of a plasma jet in Type 1 (left) and Type 2 (right).

Fig.6 and 7 show a typical waveform and the series of ICCD image of Type1 and Type 2, respectively. These images represent an integration of the light emitted from the discharge for 5 ns from the time when the camera is opened by the gating pulse. The ICCD opening time for each frame is indicated by the number enclosed with a circle under the trace of the discharge current. In Type 1, the discharge is radially homogeneous and covers the surface of the specimen. In Type 2, relatively small "plasma bullets" are observed. The plasma bullet is emitted from the powered electrode to ground electrode. The

plasma bullet and the corresponding rising edge of current pulse appear simultaneously.

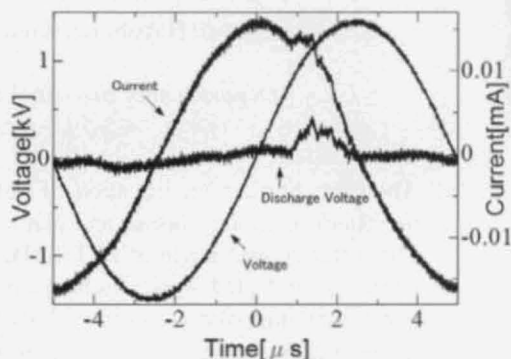

Fig.4. Waveforms of voltage and current in Type1.

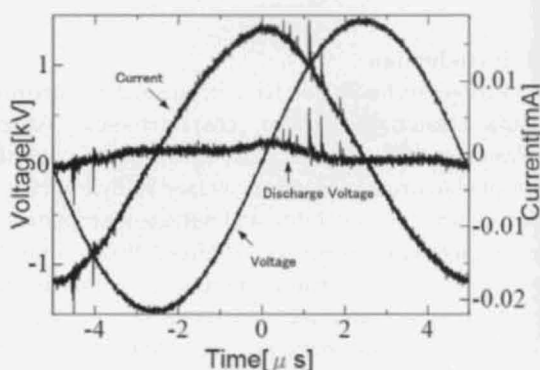

Fig.5. Waveforms of voltage and the current in Type 2.

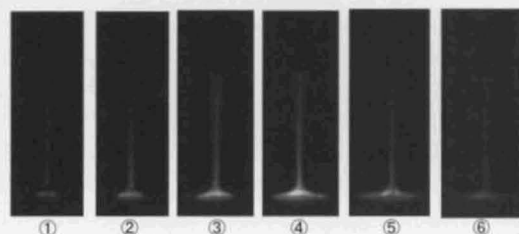
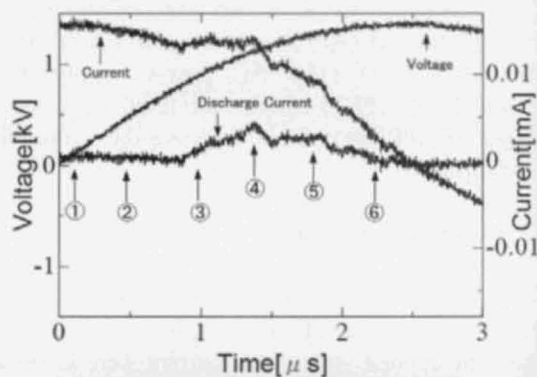

Fig.6. Waveform and framing photographs in Type1.

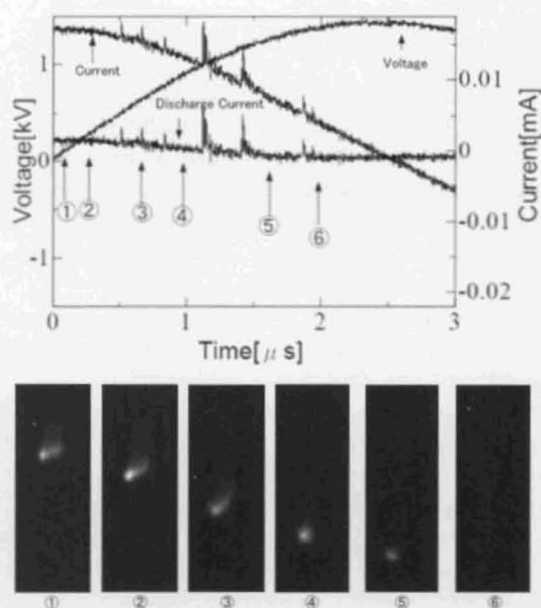

Fig.7. Waveform and framing photographs in Type2.

3.2 Water contact angle on the plasma treated PET

Figure 8 shows the photograph of water drop and the contact angle. Figure 9 shows the change of the static water contact angle of the PET surface with time. The plasma treatment was done for ten minutes. The observation was done immediately after the plasma treatment and after 1, 2 day after the processing. The contact angle observed is found to change from 62.6°, for an untreated samples, to the minimum values of 37.6° and 40.7° after the 10 seconds treatment using Type 1 and Type 2, respectively.

In the plasma processing of polymer films, one of the most problems was to achieve a long-lasting treatment effect. The change of contact angle with storage time in

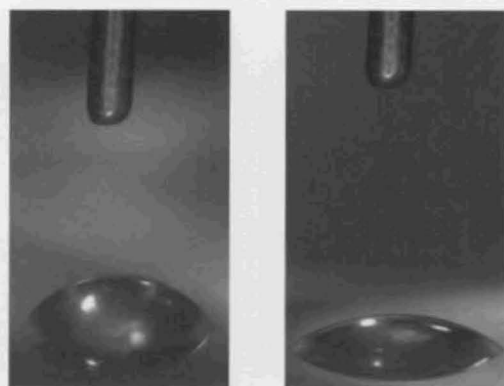

Fig.8. Photograph of contact angle of untreated (left) and plasma treated (right).

ambient air after the plasma treatment was monitored for two days. For both treatments, contact angle values are seen to increase over a period of the first or two days, and the change slowly to reach the values of 42.4° and 42.9° for the Type 1 and Type 2 treatments, respectively.

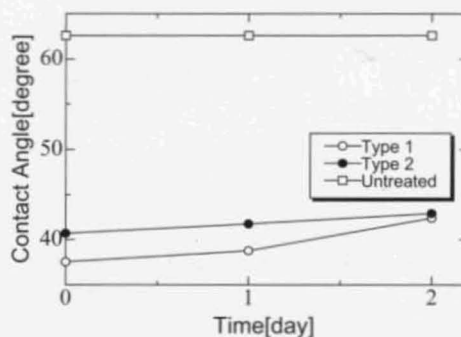

Fig.9. Post-exposure change of the static water contact angle with storage time in ambient air

3.3 XPS

The percentage of each chemical component obtained by C1s high-resolution spectra, and the detailed data are shown in Table.2. The C1s high-resolution XPS spectra of untreated and treated PET by Type 1 and Type 2 are shown in Fig 10-12. The untreated PET contains Benzene olefin groups (284.57eV), -C-OH and/or -C-O-C- groups (286.31eV) and C=O and/or -C*OO- groups (288.51eV) [4]. Besides these three peaks in the original PET, a new peaks at 290.53eV -COOH appears in the XPS spectrum of treated PET. The Benzene olefin component decreases significantly after plasma treatment, and at the same time, most of the oxygen-containing polar group such as C=O, -C-OH and -COOH increase in the surface of treated PET. This surface oxygen-containing group causes the improved hydrophilicity of plasma treated PET [5,6,7]. Comparing Type 1 and Type 2, there is much oxygen-containing group in Type 1. Because there is no visible variety of

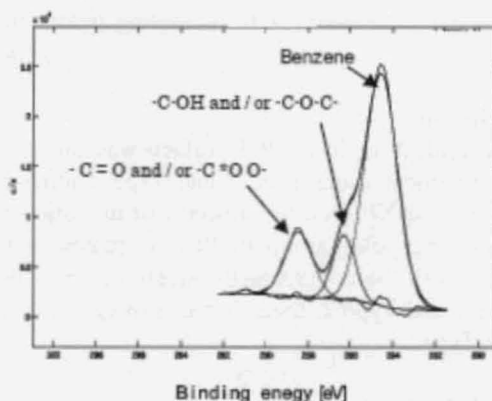

Fig.10. XPS C1s spectra of untreated PET.

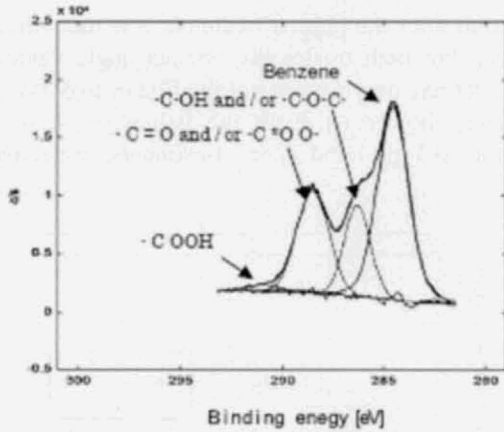

Fig.11. XPS C1s spectra of PET treated by Type1.

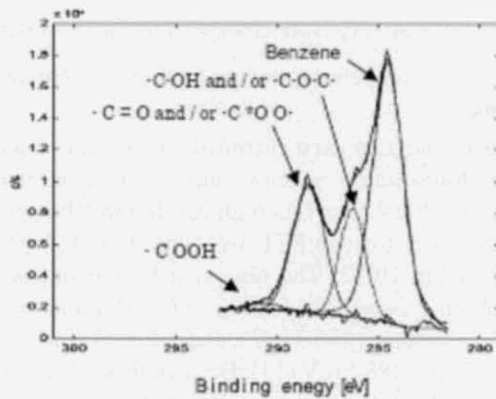

Fig.12. XPS C1s spectra of PET treated by Type2.

elements by XPS measurement, the experimental results of contact angle shown in Table.1 can be explained so that the contact angle difference was induced mostly by the difference of the ratio of oxygen containing group. The differences in surface modification between Type1 and Type 2 are related to their discharge properties. Because more active species can interact with the surface in the case of Type 1 treatment with increasing treatment time [8].

4. Conclusion

Water contact angle of PET surface was improved by plasma treatment using Type 1 and Type 2 atmospheric plasma jet. The XPS results showed that the ratio of oxygen-containing polar group in PET increases and it is consistent with the contact angle measurement. Comparing Type 1 and Type 2, there is much oxygen-containing group in Type 1.

Acknowledgement

This work was supported by Japan Science and Technology Agency (JST), Japan.

References

- [1] J. Kedzierski, J. Engemann, M. Teschke and D. Korzec : Solid State Phenomena 107.119. (2005)
- [2] M. Teschlce, J. Kedzierski and J. Engemann: 48th Annual Technical Conference Proceedings (The Society of Vacuum Coaters, Albuquerque) p.16.(2005)
- [3] Cheng Cheng, Zhang Liye, Ru-Juan Zhan: Surface & Coatings Technology 200. 6659-6665. (2006)
- [4] Lesley-Ann O'Hare, J. A. Smith, S. R. Leadley, B.Parbhoo, A. J. Goodwin, J. F. Watts: Surf. Interface Anal. 33. 617-625. (2002)
- [5] N. De Geyter, R. Morent, C. Leys, L. Gengembre, E. Payen: Surface & Coatings Technology 201. 7066-7075. (2007)
- [6] Jiangnan Lai, Bob Sunderland, jianming Xue, Sha Yan, Weijiang Zhao, Melvyn Folkard, Barry D. Michael, Yugang Wang: Applied Surface science 252. 3375-3379. (2006)
- [7] Jozef Rahel, Marcel Simor, Mirko Cernak, Miloslav Stefecka, Yoji Imahori, Masashi Kando: Surface & Coatings Technology 169-170. 604-608. (2003)
- [8] Zhi. Fang, Yucanhg. Qiu, Edmund. Kuffel : IEEJ Trans. FM 127. 519-523. (2007)

(Received December 25, 2007 ; Accepted January 26, 2008)